



Fagor Automation S. Coop.

ENCODER LINEAL MODELO: G2AP
LINEAR ENCODER MODEL: G2AP

MANUAL DE INSTALACION / *INSTALLATION MANUAL*

Manual Code: 14460213

Manual Version: 1702



Precaución / Caution

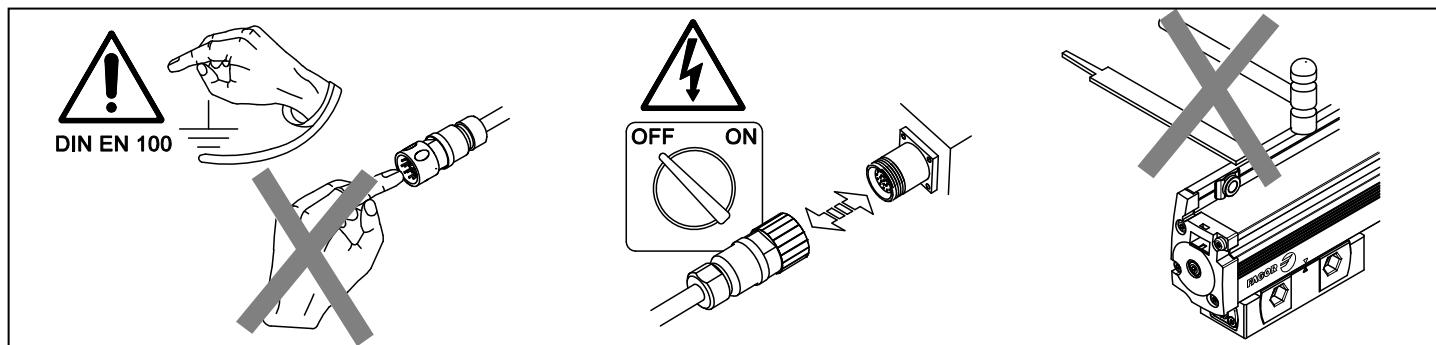

Dimensiones / Dimensions

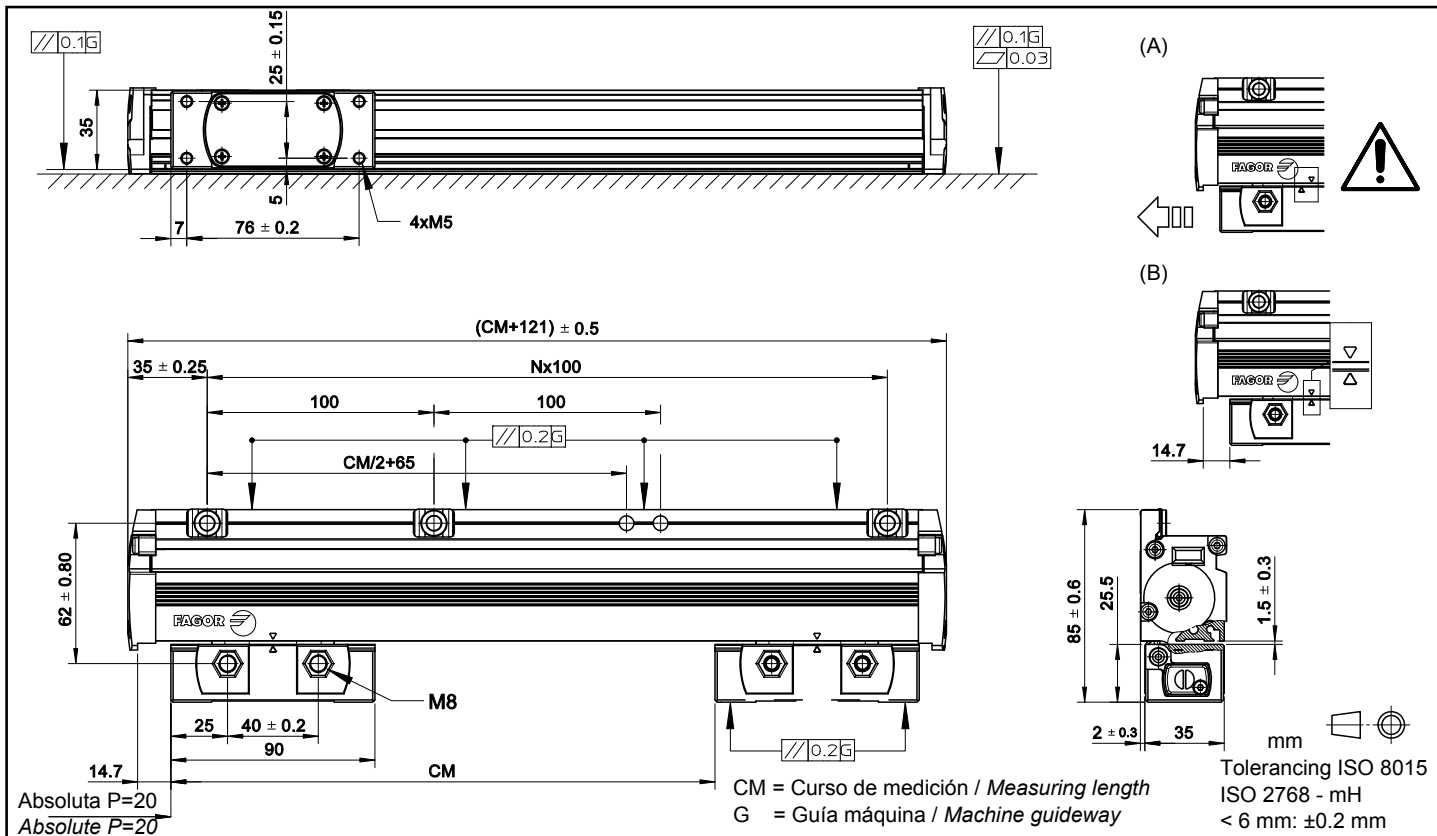

Posibilidades de montaje / Mounting possibilities

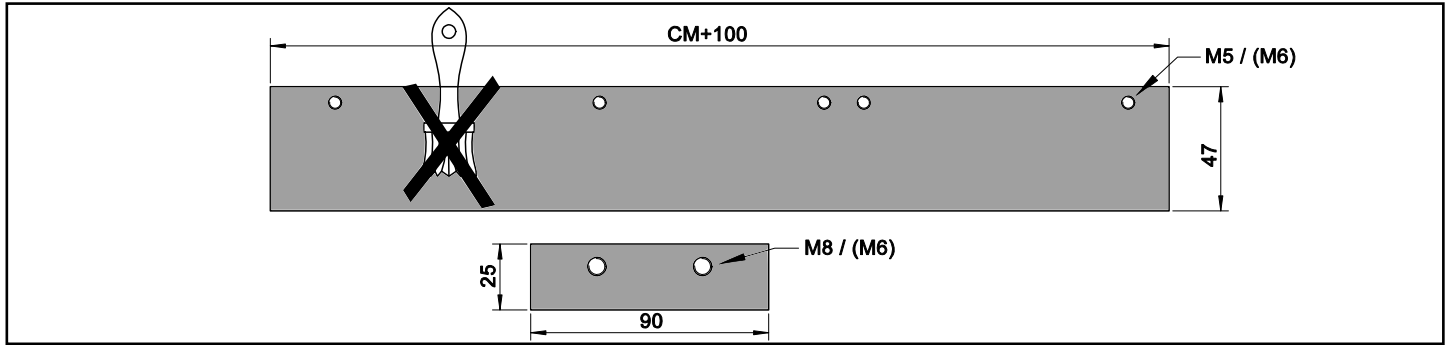

Realizar los agujeros para amarrar la regla.
El área sobreada debe estar libre de pintura.

*Make the holes to secure the scale.
The shaded area must be free of paint.*

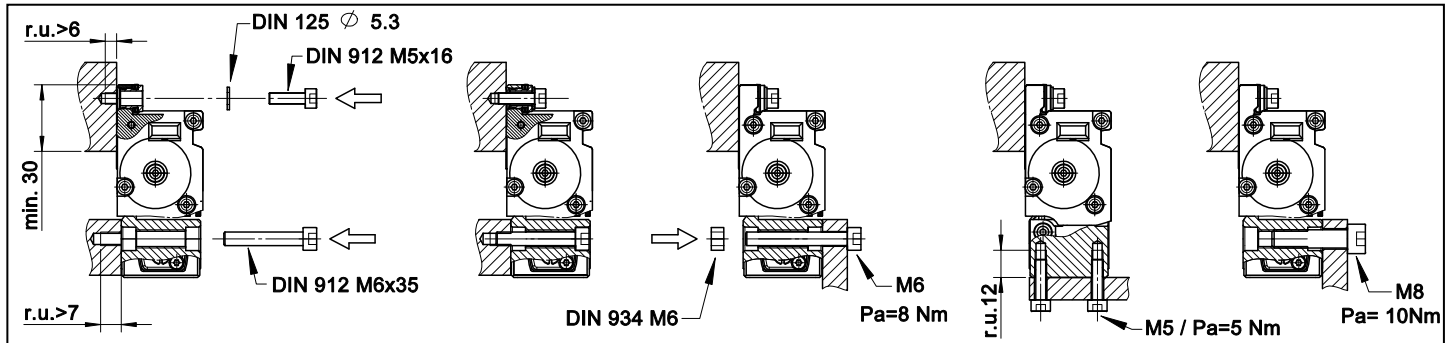

Opciones de montaje de la regla.
r.u. = rosca útil
Pa = par de apriete

*Scale mounting possibilities
r.u. = useful thread
Pa = tightening torque*

Opción cabeza con rosca M6 / M6 Threaded head option

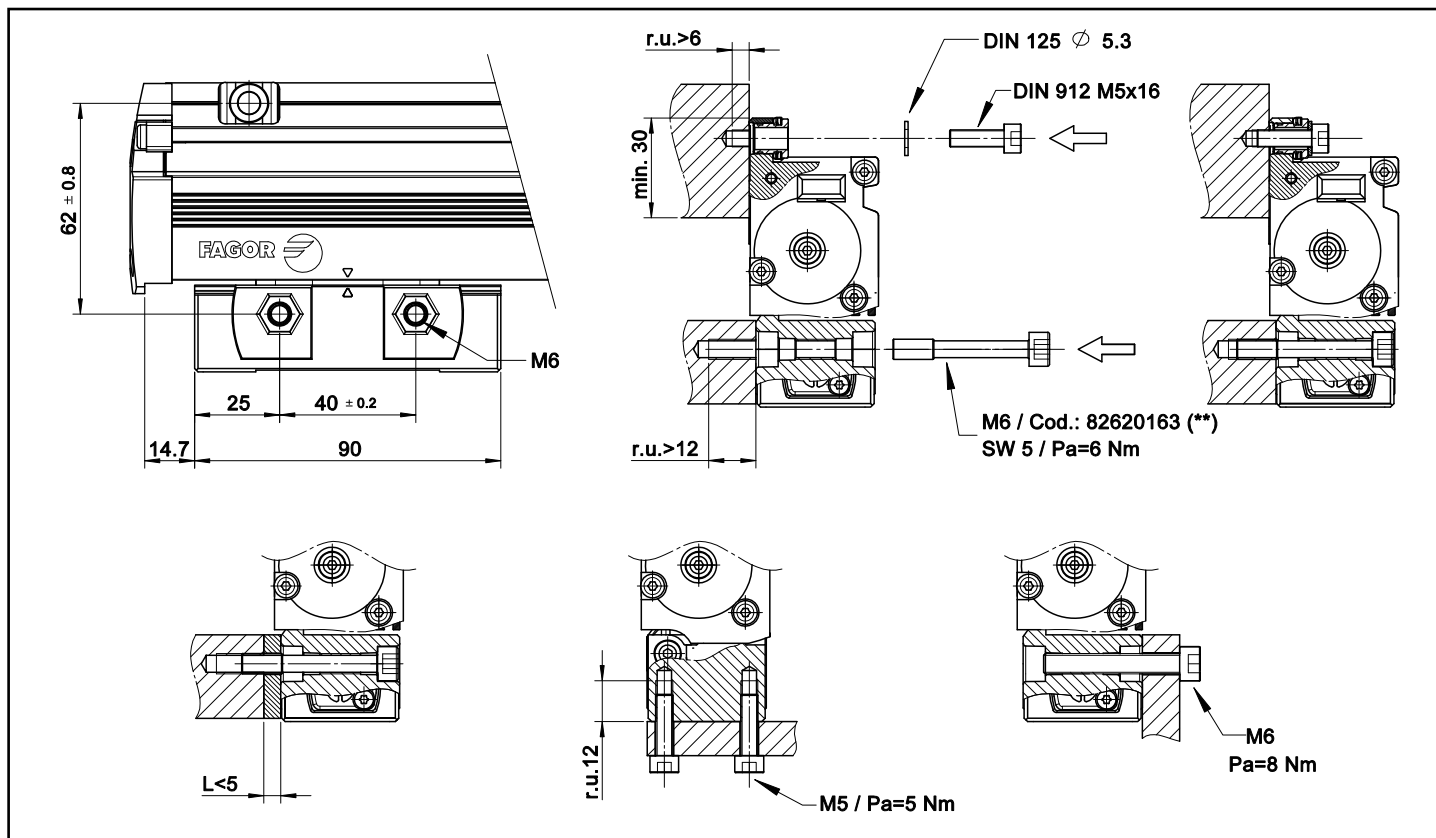

(**) Material exclusivo suministrado por Fagor. Código indicado para realizar pedido de unidades adicionales
 Exclusive material supplied by Fagor. Code shown for ordering additional units.

(SW) Tamaño de la llave hexagonal / Size of Allen wrench

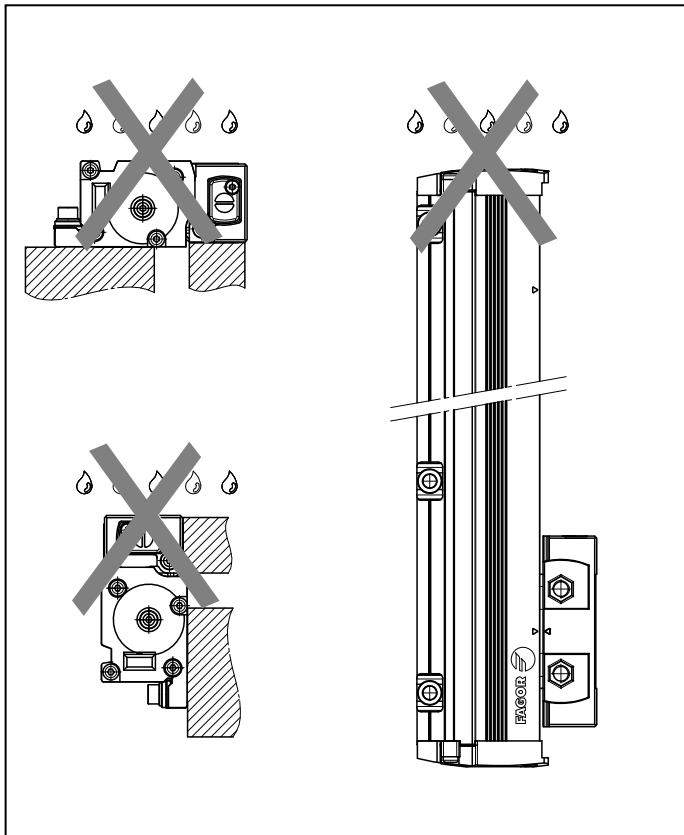

Evitar orientar los labios de estanqueidad a la exposición de posibles fuentes de contaminación
 Avoid orienting the sealing lips towards pollution sources

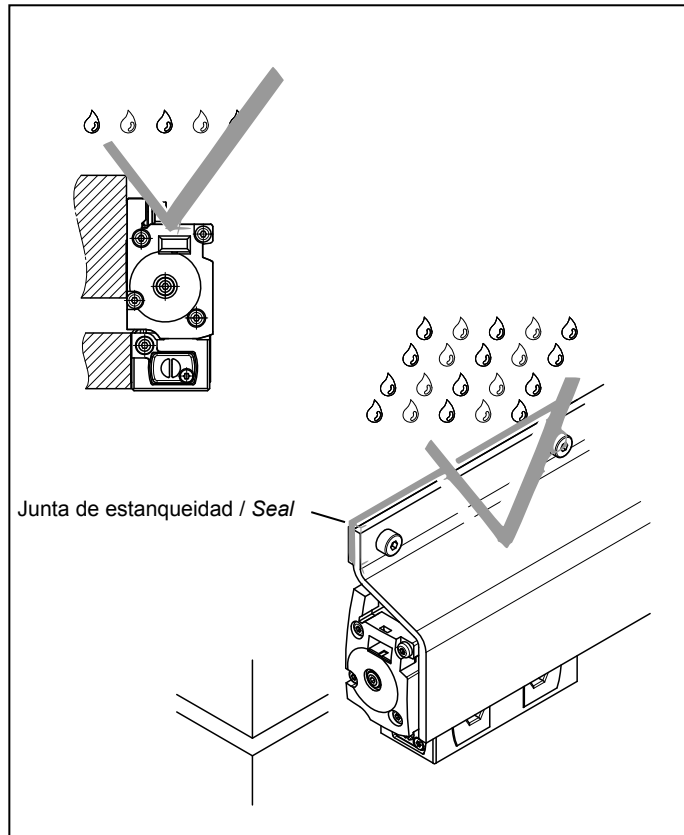

En ambientes muy contaminantes, conviene proteger la regla.
 Utilizar juntas de estanqueidad para evitar filtraciones
 In very polluted environments, the scale should be protected.
 Use seals to prevent filtrations.

Posibilidades de montaje, tolerancias / Mounting possibilities, tolerances

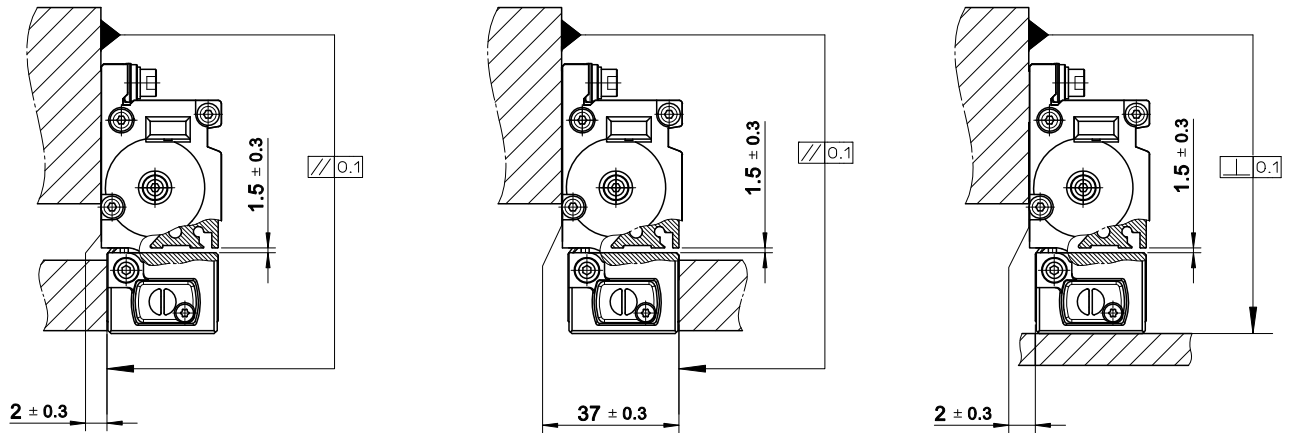

Montaje sobre tope máquina
Mounting against the machine

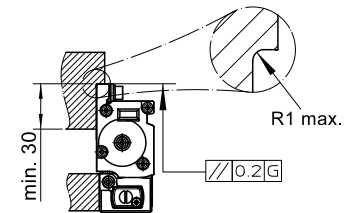

Montaje sobre pasadores
Mounting on dowel pins

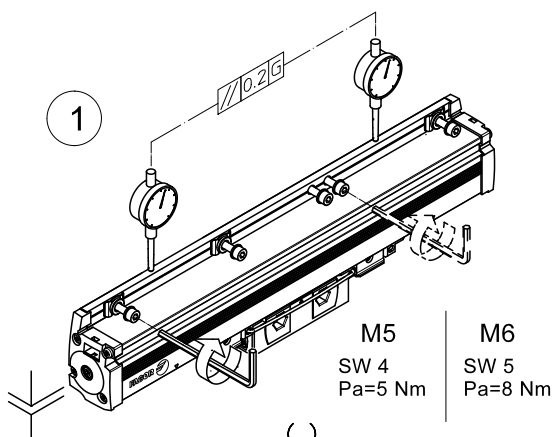
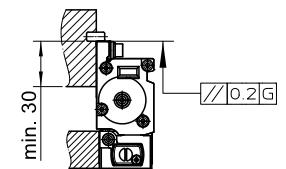

M5
SW 4
Pa=5 Nm

M6
SW 5
Pa=8 Nm

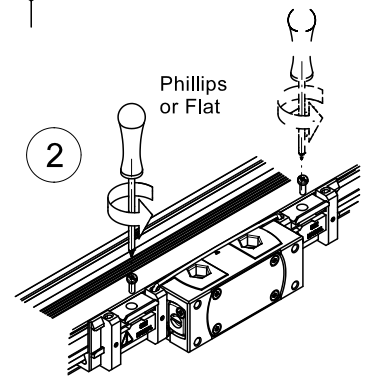

Phillips
or Flat

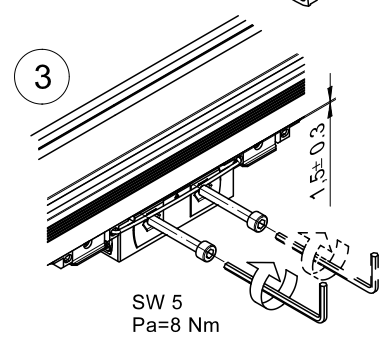

SW 5
Pa=8 Nm

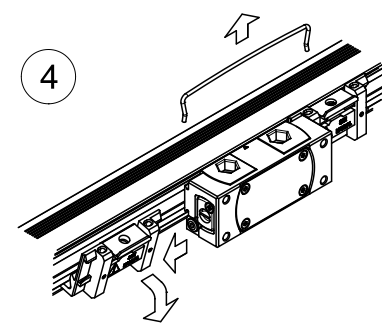

1. Premontar y alinear la regla. Una vez alineada, apretar los tornillos.
2. Quitar los tornillos de las piezas de embalaje y posicionar la cabeza.
3. Meter los tornillos de la cabeza y apretar.
4. Quitar las piezas de embalaje de la cabeza.

1. Premount and align the scale. Once aligned, fasten the screws.
2. Remove the screws of the packing parts and position the reader head.
3. Insert the head screws and fasten them.
4. Remove the packing parts of the reader head.

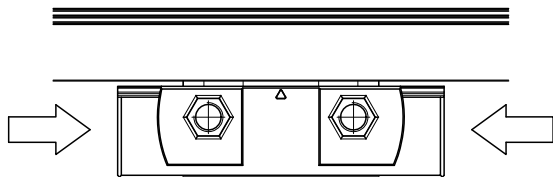

CONECTOR A AMBOS LADOS / CONNECTOR AT BOTH ENDS

Nota: Sólo conectar a un lado / Note: Only connect at one end

Para hacer la conexión: / To connect:

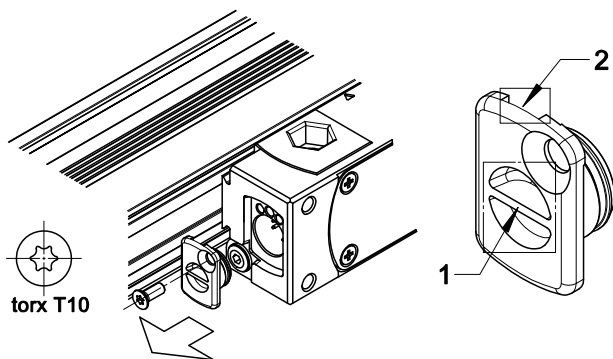

Soltar el tornillo y quitar la tapa del lado del conector
Loosen the bolt and remove the lid of the connector side

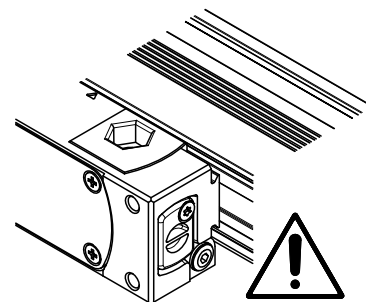

No quitar la tapa del lado no conector
Do not remove the lid of the non-connector side

Unidades de filtro de aire Fagor
Fagor air filter units

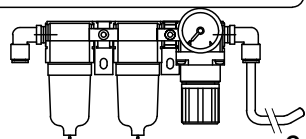

Pa = 1 Nm
SW 8



Cod.: 82620172 (*)

Para IP-64 For IP-64

1 bar / 14.5 psl / 0.1 MPa
10 l/min
Calidad aire: clase 1.4.1.
Air quality: class 1.4.1.
ISO 8573-1

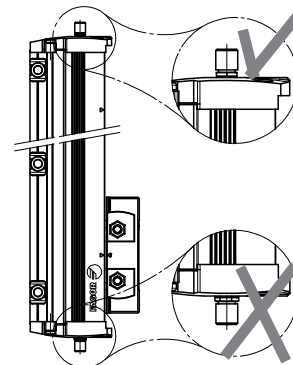
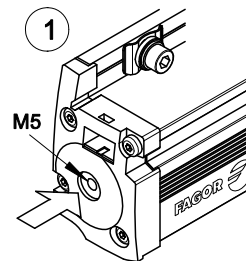

En montajes verticales no meter el aire por abajo
When mounting vertically, do not feed air from underneath

2

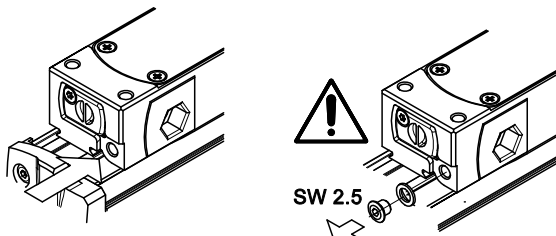
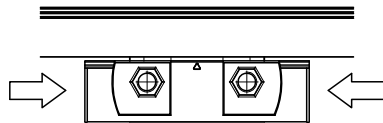

Extraer únicamente el tornillo del lado donde se va a meter el aire
Remove only the screw at the side of the air intake

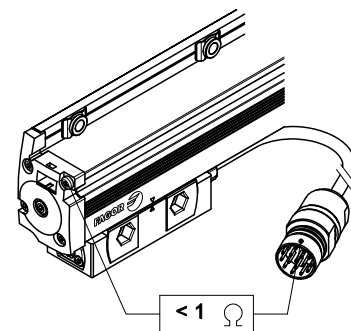
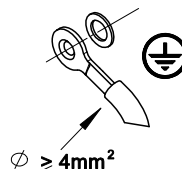

1. Entrada de aire por los tapas; posible por ambos tacos. / Air intake through endcaps; possible through both endcaps.
2. Entrada de aire por la cabeza; doble entrada de aire / Air intake through the reader head; dual air intake

(*) Material exclusivo suministrado por Fagor. Código indicado para realizar pedido de unidades adicionales
Exclusive material supplied by Fagor. Code shown for ordering additional units.

Características eléctricas / *Electrical characteristics*

	G2AP10	G2AP50
Alimentación / <i>Power supply</i>	5 V \pm 10%, 250 mA	
Resolución / <i>Resolution</i>	0.01 μ m	0.05 μ m
Longitud de cable / <i>Cable length</i>	30 m / 99 ft	
Radio de curvatura / <i>Bending radius</i>		
	Rígido / <i>Rigid</i>	Flexible
Φ 6 mm	>24 mm	> 60 mm
Φ 10 mm (con protección) / <i>(with protection)</i>	> 35 mm	> 60 mm
Φ 8 mm	> 50 mm	> 64 mm

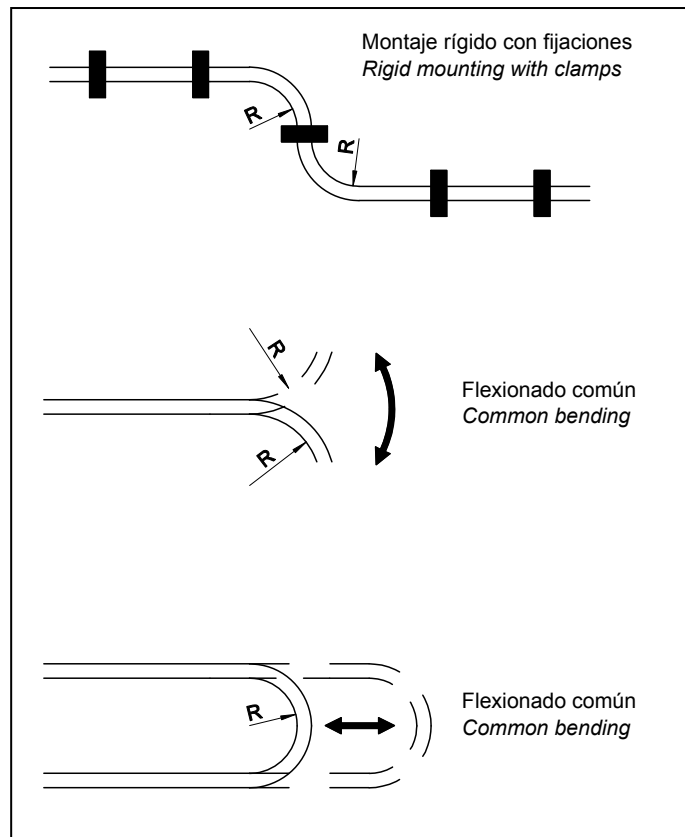

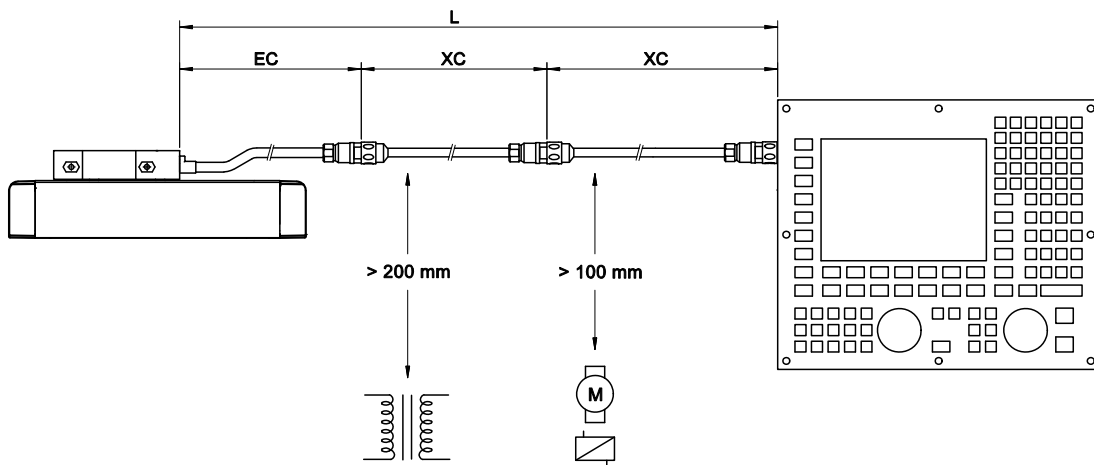

Cables para conexión de encoders absolutos Fagor a sistemas Panasonic MINAS

Cables for connection of Fagor absolute encoders to Panasonic MINAS systems

Conexión directa Cable EC

Direct connection EC cable

EC-PA-PN5 Longitud / *length* = 1, 3, 6, 9 m

Conexión con alargadera

Connection with extension cable

(5 x 2 x 0.14 mm²)

Cable EC

Alargadera intermedia opcional XCint
Intermediate extension cable optional XCint

Alargadera XC / *Extension cable XC*

EC-B-C9 Longitud / *length* = 1, 3 m

XC-C8-F-C9 Longitud / *length* = 5, 10, 15, 20, 25 m

XC-C8-A-PN5 Longitud / *length* = 5, 10, 15, 20, 25 m

EC -...B - C9	Conector circular 17 macho / <i>17-pin male round connector</i>						
PIN	14	17	7	1	10	4	Carcasa/Housing
SEÑAL SIGNAL	DATA	/DATA	+5V	+5V sensor	0V	0V sensor	Tierra /Ground
COLOR	Gris <i>Grey</i>	Rosa <i>Pink</i>	Marrón <i>Brown</i>	Verde claro <i>Light green</i>	Blanco <i>White</i>	Naranja <i>Orange</i>	Malla/Shield



EC-...B - C9

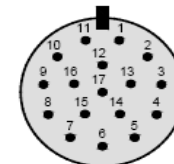

Garantía / Warranty

*Plazo: 12 meses a partir de la fecha de expedición de fábrica.

*Cubre gastos de Materiales y Mano de Obra de reparación en FAGOR AUTOMATION.

*Los gastos de desplazamiento son a cargo del cliente.

*No cubre averías por causas ajenas a FAGOR AUTOMATION, como: golpes, manipulación por personal no autorizado, etc

**Term: 12 months from factory invoice date.*

**It covers parts and labor at FAGOR AUTOMATION.*

**Travel expenses are payable by the customer.*

**Damages due to causes external to FAGOR AUTOMATION, such as unauthorized handling, blows, etc. are not covered.*

Declaración de conformidad / Declaration of conformity

Fabricante: Fagor Automation, S. Coop.

Barrio de San Andrés 19, C.P. 20500, Mondragón -Guipúzcoa- (ESPAÑA).

Declaramos bajo nuestra exclusiva responsabilidad la conformidad del producto al que hace referencia este manual

Nota. Algunos caracteres adicionales pueden seguir a las referencias de los modelos indicados en este manual. Todos ellos cumplen con las siguientes normas:

Compatibilidad electromagnética:

EN 61000-6-2:2005 Norma de Inmunidad en entornos industriales

EN 61000-6-4:2007 Norma de Emisión en entornos industriales

De acuerdo con las disposiciones de la Directiva Comunitaria: 2014/30/UE de Compatibilidad Electromagnética.

Manufacturer: Fagor Automation, S. Coop.

Barrio de San Andrés 19, C.P. 20500, Mondragón -Guipúzcoa- (SPAIN).

We declare under our exclusive responsibility the conformity of the product referred to in this manual.

Note. Some additional characters may follow the model references indicated in this manual. They all comply with the following regulations:

Electromagnetic compatibility:

EN 61000-6-2:2005 Standard on immunity in industrial environments

EN 61000-6-4:2007 Standard on emission in industrial environments

According to the European Directive: 2014/30/EU on electromagnetic compatibility.

Mondragón a 1 de febrero de 2017

Fagor Automation, S. Coop.

Mondragón February 1st, 2017.



Director Gerente
José Pérez Berdud

FAGOR AUTOMATION S. COOP.

Bº San Andrés Nº 19

Apdo de correos 144

20500 Arrasate/Mondragón

- Spain -

Web: www.fagorautomation.com

Email: info@fagorautomation.es

Tel.: (34) 943 719200

Fax: (34) 943 791712



Fagor Automation